

BURRI Public Bollard – Uni Millennium Flex

Flexible lockable bollard constructed with a predetermined break point

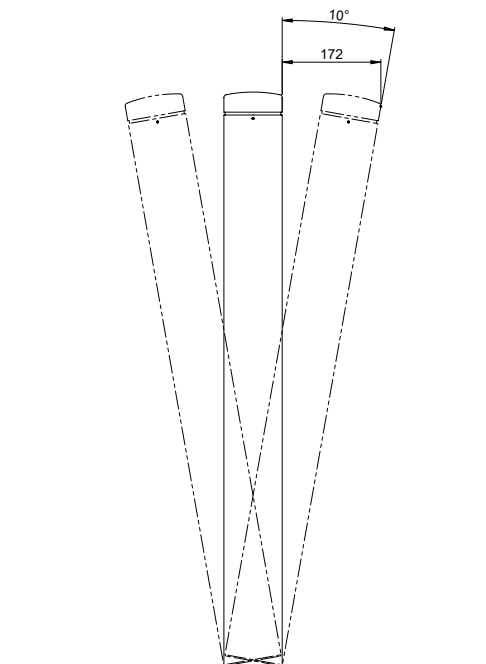

The Uni Millennium Flex barrier post is the flexible answer to leaning bollards. In the event of a collision, the Flex Zone deforms to prevent the bollard breaking and then returns it to its original position. If the impact is higher, the bollard breaks at the patented BURRI predetermined break point. As there is no damage to foundations, repairs are easily carried out and not expensive. A particularly useful feature is that the base piece is installed only 3 centimeters below the ground; a uniquely small measurement which is of great benefit particularly when bollards need to be moved after installation, as ground work is kept to a problem-free minimum.

Outwardly, the Uni Millennium Flex resembles a bollard that has been embedded in concrete; the additional function is not discernible.

The Uni Millennium Flex is available in four different versions which all offer their own benefits and advantages. Its simple design, which is based on the widely used Uni Millennium bollard, allows easy integration in any urban landscape.

Design features:

- Tubular steel
- Galvanized
- Powder-coated in anthracite

Dimensions:

- Height 1000 mm
- Diameter 101.6 mm

Application/technology

- Flex Zone up to an inclination of 10°
- Predetermined breaking point (approx. 600 kg at bumper height)
- The post is restored to full functionality following the simple replacement of the BURRI safety thread

1_ Ground sleeve for embedding in concrete

2_ Bottom plate for anchoring, min installation depth

3_ Inner threaded sleeve on a concrete slab

4_ Repair sleeve

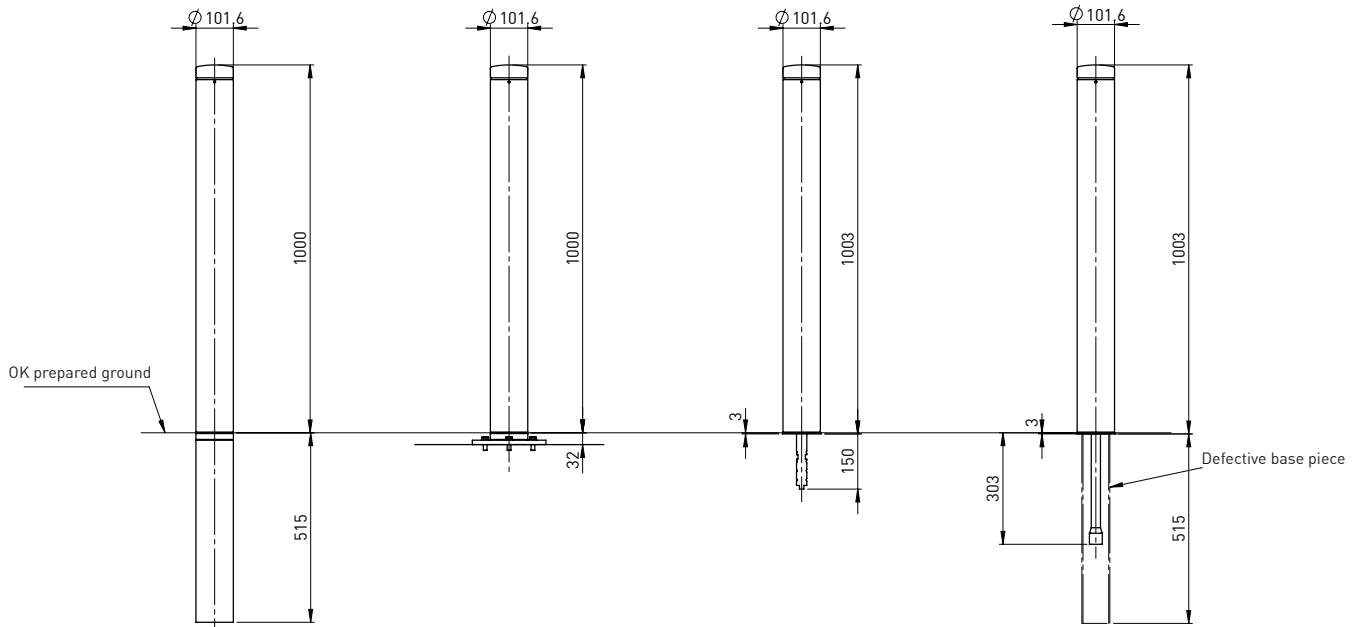

1_ Uni Millennium Flex with ground sleeve for embedding in concrete

- Bollard height 1000 mm
- Diameter 101.6 mm
- Base piece height 515 mm

The standard model: The bollard is equipped with a ground sleeve which is embedded in concrete. The bollard and the ground sleeve are joined with the predetermined break point screw and the compression joint to provide flexibility.

2_ Uni Millennium Flex with a bottom plate for anchorage

- Bollard height 1000 mm
- Diameter 101.6 mm
- Minimum depth in concrete 32 mm

The space-saving model: Thanks to an anchor plate the surface depth can be limited to a minimum of 32 millimeters. This is also suitable for later fitting and avoiding expensive and extensive ground work.

3_ Uni Millennium Flex with inner threaded sleeve on a concrete slab

- Bollard height 1000 mm
- Diameter 101.6 mm
- Inner threaded sleeve height 205 mm

The efficient model: The inner threaded sleeve on a finished concrete slab replaces the traditional ground sleeve and is screwed directly into the ground. Can be installed and moved easily and without ground works

4_ Uni Millennium Flex with repair sleeve

- Bollard height 1000 mm
- Diameter 101.6 mm
- Inner threaded sleeve height 303 mm

The repair model: The repair sleeve is used to repair damaged bollards without extensive ground works. The sleeve is inserted directly into the defective base piece.



Standard mounting

- Concrete pipe inner diameter 200 mm / length 500 mm (not included)



Special mounting

- With a special base piece and base plate for shallow mounting depth
- Enables use on surfaces where embedding in concrete is not possible for standard sleeves

Other models on request.

Options



Patented predetermined break point

Prevents damage to the surface and the bollard and guarantees low life-cycle costs. The patented safety thread can be replaced on site.



Flex Tech

Absorbs impact from small collisions with Flex Tech. More powerful impact or pressure on the bollard activates the predetermined break point.



No foundations

Fitted flush with the ground on concrete with no foundations and no base plate. Also suitable for use with bollards that have been driven over.



Smart Sensor

Smart City bollards with sensor monitoring report collisions, temperature and weather data. The range of readings can be customized.



Color and surface treatment options

Depending on where they are used, galvanized or powder-coated in a RAL or NCS color of your choice.



Flush with the ground after removal or collision

No trip hazards caused by parts protruding from the ground after removal or collision thanks to the high-quality bayonet lock.



Handrail

Stainless steel handrail / barrier can be combined in different lengths.



Chain barrier

Optionally removable with a lock or a carabiner.



Lateral barrier

For restricting access. For example, allows pedestrians to pass through, but forces cyclists to stop.



Bicycle bollards

Connection stirrups for bicycles or scooters. Different positioning options.

Accessories



Reflector strip

Reflectors in various colors and sizes



Rubber ring

Prevent scratch marks in storage